

ABSTRACT-The electricity necessities of the world including India are elevated at disturbing rate and the power demand has been increasing. The fossil fuels (i.e., coal, petroleum and natural gas) and other conventional resources, presently used for generation of electrical energy. It is not sufficient or suitable to keep Generation with ever increasing demand of the electrical energy of the world. The generation of electrical power by cold based steam power plant and nuclear power plants causes pollution, which is likely to be more harmful in future due to large generating capacity on one side and it Became tough Because greater awareness of the people in this respect. This project give idea about non - conventional Energy sources and why we are going for that non-conventional energy sources. The proper uses of solar energy and its different application which are using at home defence sector, marines, remote area etc.

INTR ODUCTION

When electricity is cut out we used solar energy and convert at in to electric energy and used for domestic purpose. A solar charger e mployes solar energy to supply electric ity to device or charger batteries. They are generally portable. A series of solar cells are installed in a stationary location and can be connected to a battery bank to store energy for off-peak usage. Most portable chargers can obtain energy fro m the sun only.

The generation of electrical power by cold based steam power plant and nuclear power plants causes pollution, which is like ly to be more harmfu l in future due to large generating capacity on one side and it Beca me tough Because greater awareness of the people in this respect.

The recent worse energy catastrophe has forced the world to grow better and substitute methods of power generation, which could be adopted easily due to its effectiveness and many various reasons. The different non-conventional methods of power generation may be such as solar cells, fuel cells, thermo-electric generator, solar power generation, wind power generation, geo-thermal energy, tidal power generation etc. This paper give idea about non- conventional Ene rgy sources and why we are going for that non -conventional energy sources. The proper uses of solar energy and its different application which are using at home, defence sector, marines, re mote areaetc.

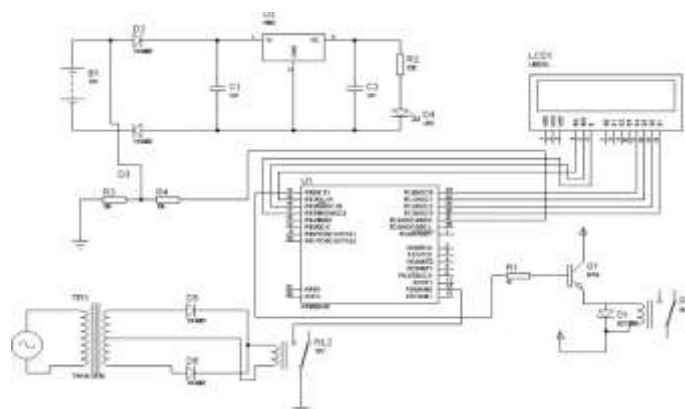

fig.1 c ircu it diagram

DESIGN CONTRA INTS

This paper will be required to take energy from the sun generated by solar panels and convert the energy to AC voltage, which will be able to power most electronic devices. The project must have a system to keep trac k of voltage levels and be able to protect the system from being overused or overcharged. It must also be able to keep

track of its solar efficiency and be able to maintain the maximum amount of solar energy possible with the given environmental and weather conditions. The biggest constraint to this project will be to maximize the solar efficiency to provide the most power to the system that can be generated by the solar panels. Weather and solar patterns must be accounted for when making all of the calculations for the efficiency and output of the solar panels. Climate factors, such as clouds, moisture, haze, dust, and smog will have a degrading effect on the output power of the station's panel array.[1]

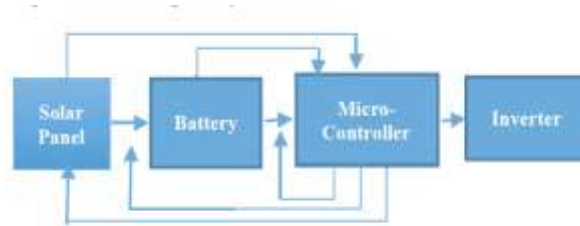

Fig. 2. Block Diagram of Circuit

SYSTEM DESIGN

We determined that this paper would need to follow the example of any electrical system. It must have a source, a function, and an output. For our source, we will be using solar panels optimized with solar tracking. The system will contain the microcontroller to act as a charge controller and an inverter to convert from 12 Volt DC stored in the batteries to 110 Volt AC as the output. Figure 2 below shows a block diagram of the system. The solar tracker would be affixed to the solar panel and would relay information to the microcontroller.

1. SOLAR PANEL TECHNOLOGY

This is the key component of any solar photovoltaic system, which takes the sun's energy and converts it into the electrical current. The process of converting light (photons) to electricity (voltage) is called the solar photovoltaic (PV) effect. Photovoltaic solar cells convert sunlight directly into solar power (electricity). They use thin layers of semi-conducting material that is charged differently between the top and bottom layers. The semi-conducting material can be encased between a sheet of glass and or a polymer resin. When exposed to daylight, electrons in the semi-conducting material absorb the photons, causing them to become highly energized. These move between the top and bottom surfaces of the semi-conducting material. This movement of electrons generates a current known as a direct current (DC).

Types Of Solar Panel

- Monocrystalline Panels
- Polycrystalline Panels
- Hybrid Panels

➤ Black Backed Panels



Fig- 3 Solar Panel

2. SOLAR TRACKER

Solar trackers provide a precise tracking of the sun by tilting the solar panels towards the sunlight as it moves throughout the day and as well, the year. When sunlight strikes a solar panel, it comes in at an angle, called the angle of incidence. The normal angle to the cell is perpendicular to a PV cell's face and this normal is necessary to achieve the panel's proper alignment towards the sun. A tracking system can keep the angle of incidence within a certain margin and would be able to maximize the power generated.

Trackers are categorized as either a single axis or dual axis system. Single axis accounts for horizontal east to west daily movement while dual axis integrates a vertical north and south seasonal tilt into the system. Single axis can provide a 15% to 30% increase of efficiency and solar power generated over a stationary panel while dual axis provides an additional 6% [2]. The cost comparison for implementing a dual axis tilt tracker vs. single axis shows that dual axis will not be cost effective for this project because of the complexity and maintenance of the mechanics. Less components, in this case, will mean greater reliability and less down-time for maintenance issues.[3]

3. CHARGE CONTROLLER

The Charge Controller is a switching device that can connect and disconnect the charger to the battery and it will take control over charging and to stop charging at the correct voltage. This will protect the batteries from damage from over-charging and regulate the power going from the solar panels to the batteries. A microcontroller in the circuit will read the level of the batteries and then cut off the source of the solar panels to the batteries, once it sees the battery is at the fully charged state. If this was not in place, the solar panels would keep feeding the batteries energy and the batteries would become overheated and damage the internal components. The advantage to have a microcontroller in the system is that it will open a variety of features to add to the system. For example the microcontroller will be programmed to control and display the battery level of the system.

4. BATTERY

The team has selected two deep cycle batteries to power the system. Each battery is a 12V and has a 35 Amp-hour

Capacity. Batteries for PV system batteries generally have to discharge a smaller current for a longer period of time, such as at night or during a power outage, while being charged during the day. Deep cycle batteries are designed for the purpose of discharging to a lower capacity, between 50% and 80%, than a conventional battery. The most commonly used deep-cycle batteries are lead-acid batteries and nickel-cadmium batteries, both of which have pros and cons. The deep-cycle batteries are able to be easily charged and discharged many times and can last for several years due to the thicker plate materials utilized. Batteries in PV systems can also be very dangerous because of the energy they store and the acidic electrolytes they contain, so you'll need a well-ventilated, nonmetallic enclosure for them.

5. INVERTER

An inverter is an integral component in the solar station's design. It will convert the DC voltage generated from the solar panels to an AC voltage. The team will be testing two designs by using special ICs or several pairs of transistors and diodes. An inverter can produce square wave, modified sine wave, pulsed sine wave, or sine wave depending on circuit design, demonstrated in Figure 2. The two dominant commercialized waveform types of inverters as of 2007 are modified sine wave and sine wave. There are two basic designs for producing household plug-in voltage from a low-voltage DC source, the first of which uses a switching boost converter to produce a higher-voltage DC and then converts to AC. The second method converts DC to AC at battery level and uses a line-frequency transformer to create the output voltage.

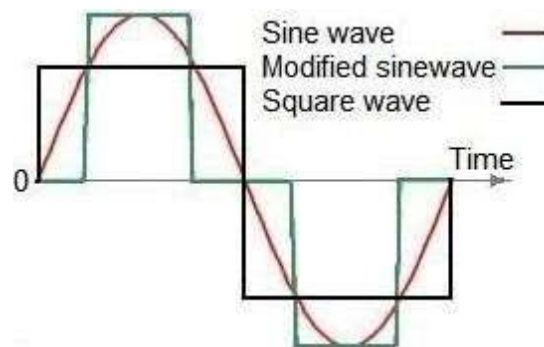

Fig. 4 Sample inverter outputs

Inverter circuits can have a power loss of 10% or even up to 20%. The team anticipates for a larger power inverted based on our maximum expected output and that the largest output will be required when two laptops are plugged into the system. Generally, laptops can draw anywhere between 65-90 Watts. For two laptops rated at 90 Watts, the inverter will be required to generate 180 Watts. From our calculation, we determined a 200 Watt inverter will suffice. At a 90% efficiency (10% power loss), the inverter will generate the 180 Watts we need.[4]

SUMMARY

This System provides portable, reliable power anywhere it is needed... from off-grid construction sites, to remote locations where power is not accessible or affordable, and without the associated with traditional fuel-driven generators. Flexible Panel Systems are designed for highly mobile applications where a small footprint & high power is required. Systems provide power platforms that are versatile, effective, and multi-faceted. Portability is a key feature of the System can be assembled or removed in minutes, allowing for rapid deployment in the field. The system can be deployed and operational for just an hour, or indefinitely. It is as temporary or permanent as necessary.

CONCLUSION

In this paper solar battery which connect to the supply line parallel of the solar battery charge. It is brake the power supply which using 8051 micro controller through operate the solar battery charge is a flow of the best in the future life. This System provides portable, reliable power anywhere it is needed... from off-grid construction sites, to remote locations where power is not accessible or affordable, and without the associated with traditional fuel-driven generators.

REFERENCE

1. George Johnson "Plugging into The Sun" , National Geographic magazine, Sept. 2009.
2. C.E.Kennedy and H.Price "Progress In Development of High Temperature Solar Selective Coating", Proceedings of ISEC2005, August 6-12 2005, Orlando, Florida, USA.
3. John, Keit, Solar Battery Charger Circuit", <http://www.electroschematics.com/6888/> [Online] (Retrieved 08/04/2015)
4. Electroshub, (2015). "Solar Battery Charger Circuit using LM317 Voltage Regulator", <http://www.electronicshub.org/solar-battery-charger-circuit/> [Online] (Retrieved 07/ 15/ 2015)