

SMART RAILWAY GATE SYSTEM¹Miss.Mhetre M.B., ²Ms. Awate Priti, ³Ms.Mhetre SakshiLecturer, Department of Electronics & Telecommunication Engineering, SVSMD's KKI Polytechnic, Akkalkot, Maharashtra, India.¹Student, Department of Electronics & Telecommunication Engineering, SVSMD's KKI Polytechnic, Akkalkot, Maharashtra, India.^{2,3}Lmdongaritot@gmail.com**ABSTRACT**

Railway transportation is one of the most widely used modes of transport due to its efficiency, affordability, and ability to carry large numbers of passengers and goods. However, accidents at railway level crossings remain a significant safety concern, particularly at unmanned or manually operated railway gates. Human errors, delayed gate operations, and lack of timely warning systems can lead to serious accidents, resulting in loss of life and property. Therefore, the development of an intelligent and automated railway gate control system is essential to improve safety and operational efficiency.

This research presents the design and implementation of a Smart Railway Gate System that automatically controls the opening and closing of railway gates based on train detection. The proposed system utilizes sensors, a microcontroller, and a gate control mechanism to ensure safe and reliable operation. Sensors placed at predefined distances from the railway crossing detect the arrival and departure of trains. Upon detecting an approaching train, the microcontroller processes the sensor signals and automatically closes the gate while simultaneously activating warning indicators such as LEDs and buzzers to alert road users. After the train safely passes the crossing, the system reopens the gate, restoring normal road traffic flow.

The proposed system minimizes the need for manual intervention and significantly reduces the possibility of accidents caused by human negligence. It also improves traffic management by ensuring timely gate operation and reducing unnecessary waiting times for vehicles. The system is cost-effective, reliable, and suitable for deployment at both urban and rural railway crossings. Experimental evaluation demonstrates that the Smart Railway Gate System provides accurate train detection, rapid gate response, and enhanced safety performance. Furthermore, the system can be integrated with modern technologies such as the Internet of Things (IoT), wireless communication, and centralized railway monitoring systems to support future smart transportation infrastructure.

Keywords: *Smart Railway Gate, Railway Safety, Automatic Gate Control, Train Detection, Microcontroller, Embedded Systems, Transportation Automation.*

INTRODUCTION

Railways play a vital role in the transportation sector by providing a reliable, economical, and efficient means of travel and freight movement. As railway networks continue to expand to accommodate increasing passenger and cargo demands, ensuring safety at railway crossings has become a major challenge. Railway level crossings are critical points where roadways intersect with railway tracks, requiring effective coordination between road and rail traffic. Any failure in managing these intersections can result in severe accidents, causing injuries, fatalities, and substantial economic losses.

Traditionally, many railway gates are operated manually by gatekeepers who are responsible for monitoring train movements and controlling gate operations. Although manual gate control has been widely used for decades, it is

susceptible to human errors such as delayed gate closure, communication failures, fatigue, and negligence. In remote and rural areas, numerous railway crossings remain unmanned, increasing the risk of collisions between trains and road vehicles. These challenges highlight the need for an automated and intelligent railway gate management system capable of operating with high accuracy and reliability.

Recent advancements in embedded systems, microcontrollers, sensors, and automation technologies have enabled the development of smart transportation solutions. Automation reduces dependence on human intervention and enhances operational efficiency. In the context of railway safety, automatic gate control systems can detect approaching trains and operate crossing gates without requiring manual supervision. Such systems improve safety by ensuring timely gate closure before the train reaches the crossing and reopening the gate immediately after the train has passed.

The Smart Railway Gate System proposed in this research employs train detection sensors, a microcontroller-based control unit, warning indicators, and an automated gate mechanism. Sensors installed along the railway track continuously monitor train movement. When a train approaches the crossing, the sensor signals are transmitted to the microcontroller, which processes the information and activates the gate control mechanism. The gate closes automatically, and warning devices such as buzzers and signal lights are activated to notify road users. Once the train passes the crossing and is detected by the exit sensor, the system automatically opens the gate and resumes normal traffic operations.

The implementation of a Smart Railway Gate System offers several advantages over conventional manual gate operation. It reduces accident risks, improves traffic management, minimizes human errors, and enhances overall railway crossing safety. Additionally, automated systems provide consistent performance under varying environmental conditions and can operate continuously without fatigue. The proposed solution is designed to be cost-effective and scalable, making it suitable for deployment in both urban and rural railway networks.

With the growing adoption of smart transportation technologies, intelligent railway crossing systems are expected to become an integral part of future railway infrastructure. The integration of sensors, wireless communication, cloud monitoring, and IoT technologies can further enhance the capabilities of railway gate automation systems. Therefore, the Smart Railway Gate System represents a significant step toward improving transportation safety, operational efficiency, and the development of intelligent railway networks.

LITERATURE REVIEW

Railway transportation is one of the safest and most efficient modes of transport; however, accidents occurring at railway level crossings continue to be a major concern worldwide. Researchers have extensively studied automated railway gate control systems to improve safety, reduce human intervention, and enhance transportation efficiency. Various technologies such as microcontrollers, sensors, wireless communication, Internet of Things (IoT), and artificial intelligence have been employed to develop smart railway gate systems.

Several researchers have proposed automatic railway gate control systems using infrared (IR) sensors for train detection. In these systems, sensors are placed on either side of the railway crossing to detect the arrival and departure of trains. When a train is detected, a microcontroller automatically closes the gate and reopens it after the train passes. These systems demonstrated improved safety and reduced dependence on manual gate operators. However, their performance can be affected by environmental factors such as dust, fog, and sensor misalignment. Many studies have utilized microcontroller-based automation systems using platforms such as Arduino, PIC, and ATmega controllers. These systems process signals received from sensors and control gate motors through

programmed logic. Researchers reported that microcontroller-based solutions are cost-effective, easy to implement, and highly reliable for small- and medium-scale railway crossing applications. The flexibility of microcontroller programming also allows integration with additional safety features such as warning lights and alarm systems.

Recent developments in wireless communication have encouraged researchers to integrate GSM, RF, ZigBee, and Wi-Fi technologies into railway gate automation systems. GSM-based systems enable communication between trains and railway control centers through mobile networks, allowing remote monitoring and control. ZigBee and RF communication systems provide wireless data transmission between sensors and control units, reducing wiring complexity. Although these technologies improve monitoring capabilities, they may increase implementation costs and require additional communication infrastructure.

With the advancement of IoT technology, several researchers have proposed smart railway gate systems connected to cloud platforms. IoT-based systems allow real-time monitoring of railway crossings, remote diagnostics, and centralized control of multiple gates. Data collected from sensors can be transmitted to cloud servers, enabling railway authorities to monitor gate status and train movement from any location. These systems offer enhanced scalability and operational efficiency but require stable internet connectivity and cybersecurity measures.

Some researchers have explored the use of RFID (Radio Frequency Identification) technology for train detection and identification. RFID tags installed on trains communicate with RFID readers placed near railway crossings. The system can accurately identify approaching trains and trigger gate operations accordingly. RFID-based solutions provide high accuracy and reliability; however, the installation and maintenance costs may be higher compared to conventional sensor-based systems.

WORKING

The Smart Railway Gate System operates automatically by detecting the arrival and departure of trains using sensors placed near the railway crossing. The system consists of train detection sensors, a microcontroller, a motor driver circuit, a gate control mechanism, and warning indicators such as LEDs and buzzers.

When a train approaches the railway crossing, the first sensor (Sensor 1) detects its presence and sends a signal to the microcontroller. The microcontroller processes the signal and activates the warning indicators to alert road users. Simultaneously, it controls the motor driver circuit to close the railway gate before the train reaches the crossing. The gate remains closed while the train passes through the crossing.

After the train completely crosses the gate area, the second sensor (Sensor 2) detects the departure of the train and sends a signal to the microcontroller. The microcontroller then deactivates the warning indicators and operates the motor in the reverse direction to open the railway gate. Normal road traffic resumes once the gate is fully opened.

This automatic operation eliminates the need for manual gatekeepers, reduces human errors, improves traffic management, and significantly enhances safety at railway crossings.

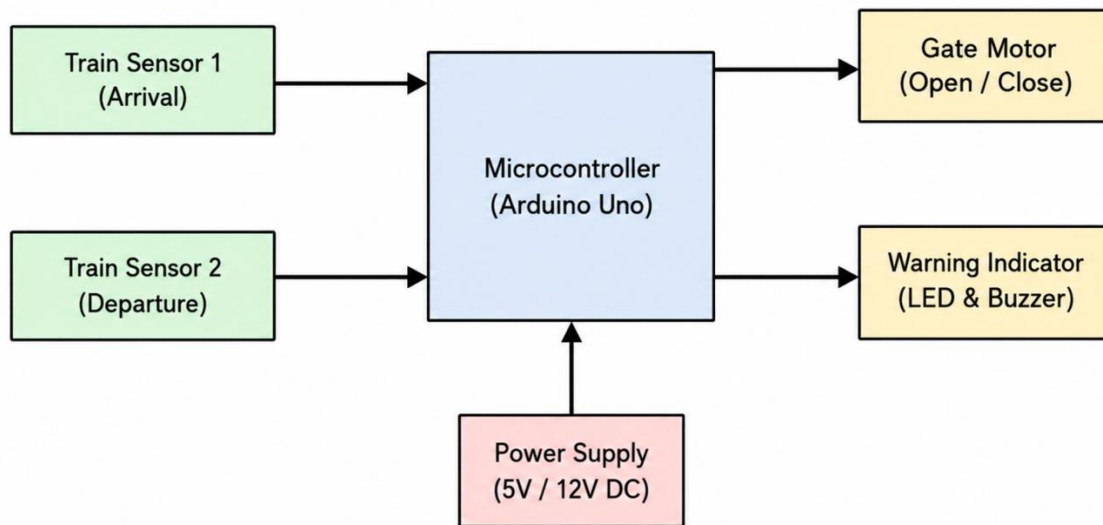

Fig 1: Block Diagram

Scope of the project

The scope of the Smart Railway Gate System is to automate the operation of railway crossing gates using sensors and a microcontroller. The system detects approaching and departing trains, automatically controls gate movement, and provides warning signals to road users. It aims to improve railway crossing safety, reduce human intervention, and minimize accidents at both manned and unmanned railway crossings. The system can be further enhanced through IoT-based monitoring and remote control features.

Objectives of the Project

1. To design and develop an automatic railway gate control system.
2. To detect train arrival and departure using sensors.
3. To automatically open and close railway gates without human intervention.
4. To provide warning indications using LEDs and buzzers.
5. To improve safety at railway level crossings and reduce accidents.
6. To develop a reliable and cost-effective railway automation solution.

CONCLUSION

The Smart Railway Gate System is an effective and reliable solution for improving safety at railway level crossings. The system automatically detects the movement of trains using sensors and controls the opening and closing of railway gates through a microcontroller-based mechanism. By eliminating the need for manual gate operation, the proposed system reduces human errors and enhances operational efficiency.

The automatic activation of warning signals such as LEDs and buzzers helps alert road users in advance, thereby reducing the possibility of accidents. The system provides timely gate operation, ensures smooth traffic management, and improves the overall safety of railway crossings. Due to its simple design, low cost, and ease of implementation, the proposed system can be deployed at both urban and rural railway crossings. Thus, the Smart Railway Gate System offers a practical and efficient approach toward modern railway safety and automation.

RESULT

The developed Smart Railway Gate System was successfully implemented and tested. The sensors accurately detected the arrival and departure of trains and transmitted signals to the microcontroller. Based on these signals, the microcontroller controlled the gate mechanism and warning indicators effectively.

The railway gate closed automatically when a train approached the crossing and reopened after the train safely passed. The LED and buzzer warning system operated correctly during train movement, providing clear alerts to road users. The system demonstrated reliable performance, quick response, and stable operation throughout testing.

REFERENCES

1. S. Chandra and M. M. Agarwal, *Railway Engineering*, Oxford University Press, 2018.
2. F. Vahid and T. Givargis, *Embedded Systems Design*, Wiley Publications, 2019.
3. M. Banzi and M. Shiloh, *Getting Started with Arduino*, Maker Media, 2022.
4. A. Sharma and P. Gupta, "Automatic Railway Gate Control System Using Microcontroller," *IJERT*, vol. 9, no. 6, 2020.
5. R. Kumar and V. Singh, "Smart Railway Crossing System Using Embedded Technology," *IJAR CET*, vol. 8, no. 4, 2019.
6. M. Patel and D. Shah, "Railway Gate Automation Using Arduino and Sensors," *IJSREM*, vol. 5, no. 2, 2021.
7. S. Verma and A. Mishra, "IoT-Based Smart Railway Gate Monitoring and Control System," *IJRSE*, vol. 7, no. 3, 2022.
8. K. Rao and P. Reddy, "Automatic Railway Gate Control and Accident Prevention System," *IJCA*, vol. 175, no. 18, 2020.
9. *Arduino Uno Datasheet*, Microchip Technology Inc.
10. *IEEE Xplore Digital Library*, Research Papers on Smart Railway Gate Systems and Railway Safety Automation.

E-ISSN NO:2349-0721