



PERFORMANCE OF MODULAR MULTILEVEL CONVERTER BASED STATCOM IN POWER QUALITY PROBLEMS

Ms. Bhagyashree B.Thool

Dept. of Electrical Engineering
S.D.C.O.E, Selukate, Wardha
Maharashtra, India
bhagyshreethl@gmail.com

Mr. K. N. Sawalakhe

Dept. of Electrical Engineering
S.D.C.O.E, Selukate, Wardha
Maharashtra, India

Prof. N. A. Wanjari

Dept. of Electrical Engineering
S.D.C.O.E, Selukate, Wardha
Maharashtra, India

ABSTRACT

This paper presents the Performance of Modular Multilevel Converter based STATCOM in Power Quality Problems. MMC based STATCOM have many feature over conventional Voltage source converter like Transformer less operation, Sub Modular structure, low expensive due to un necessity of filters redundancy and fault tolerant operation, standard components are used, low PWM carrier Frequency and quality of output waveforms. Due to the advantages of Modular Multilevel Converter over other converter topology it is used as Power Stages in STATCOM. Performance of Modular Multilevel Converter based STATCOM at various conditions are studied in this paper.

Key words

Modular Multilevel converter, STATCOM, Voltage source Converter (VSC)

INTRODUCTION

In recent years Modular Multilevel Converter is an emerging and promising converter topology use for medium to high power converter which is introduced by Prof. R Marquardt et al in 2001. MMC is used for various applications, such as renewable energy, smart grid, FACTS, and HVDC systems [1-6]. The technological advancement have proven a path to the modern industries to extract and develop the innovative technologies within limit of their industries for fulfillment of their industrial goal. And their ultimate objective is to optimize the production while minimizing the production cost and there by achieving maximized profits while ensuring continuous production throughout the period.

Multilevel converter can be classified as shown in Fig.1. In which Multi cell Topology is advance topology over two level or three level voltage source converter since its simple realization of redundancy due to large number of cells used, power semiconductor losses are reduced and no filter requirement, the lowest expense, higher voltage levels, modular construction, longer maintenance intervals and improved reliability and the lowest harmonic content due to the large number of output voltage levels they produce. Large number of

cells required increase in converter control unit offers simple structure hence cost of manufacture is reduced. Modular multilevel converter among Multi cell topology of Multilevel converter offers additional feature.

- 1) Transformer less operation and common DC Bus.
- 2) The PWM carrier frequency is low. Hence reduced losses.
- 3) AC voltage and current contain low harmonics, passive filters becomes unnecessary.
- 4) System has fast recovery.
- 5) No bulky capacitors are required.[1]

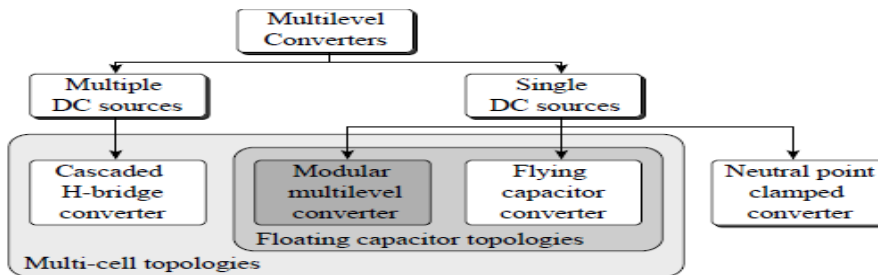

Fig.1.Multilevel Converter classification .

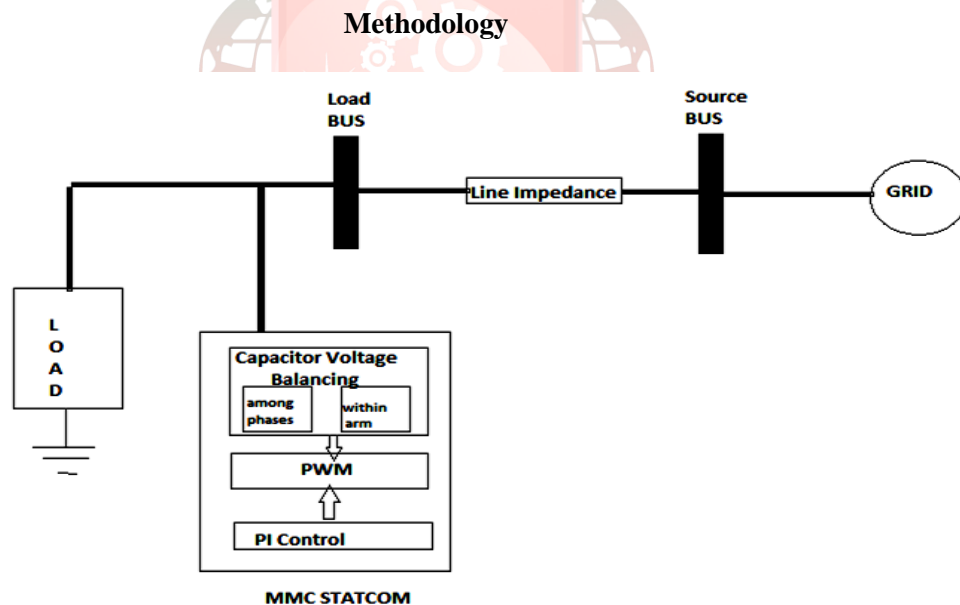

Fig. 2. Proposed methodology Diagram

MMC STATCOM can be studied by using above Block diagram. Load is connected to PCC. STATCOM can be connected on either side i.e towards load side or Source side.

The MMC STATCOM topology consists of different blocks. Which are illustrated in brief as below.

Capacitor Voltage Balancing

In the MMC, modules are constantly inserted into and bypassed out of the system. In order to keep the capacitor voltages as evenly distributed as possible, not any module should be operated at

any given time. The modules inserted or bypassed have to be selected. Failure to adequately balance the voltages not only distorts the output voltage but also can result in equipment damage if individual module voltages fluctuate outside of the rated values of the equipment. This selection is based on the direction of the current in the arm. The change of a given module's capacitor voltage is dependent on its inserted/bypassed state, as well as the magnitude and direction of the arm current. When the module is inserted, the capacitor voltage increases (decreases) if the current is flowing into (out of) the module. On the other hand, if the module is in the bypassed state, the capacitor voltage remains unchanged. This fact can be used to balance the capacitor voltages. If a module voltage is lower (higher) than the average voltage per arm, it should be inserted (bypassed) when the arm current is such that it will charge the module capacitor, and bypassed (inserted) otherwise. Using as a reference, if a module is inserted in an arm and current flows through it in the positive direction, this current will cause its capacitor voltage to increase..

Phase-Shifted Sinusoidal Pulse-Width Modulation (PS-SPWM)

A force switching strategy is to implement Sinusoidal Pulse Width Modulation for each module individually, while time shifting the different switching times for each module to take advantage of the modularity of the MMC. As in regular SPWM, the signal to be modulated is compared to a high frequency triangular waveform. To take advantage of the higher number of levels, PS-SPWM uses as many different phase-shifted triangular waveform as there are converter levels. The waveforms are phase-shifted so that the switching instants of the different modules are offset in time, thus reducing the harmonics in the output signal, In the example, the frequency of the triangular waveform is 360Hz, only 6 times that of the modulating signal. It can be seen in the graph showing the harmonic contents of the modulating signal however, that the apparent switching frequency is much higher, in this case, the lower harmonics are centered around 1800Hz, 5 times higher than the individual modules switching frequency as there are 5 modules per arm. This illustrates a major advantage of the MMC, which is a substantial reduction in losses as each module switches at only a fraction of the overall equivalent switching frequency. This advantage becomes more attractive as the number of modules increases, either producing a higher apparent output frequency, or lowering the switching frequency of individual modules. From the figure, the underlying sinusoidal waveform can easily be noticed. Compared to the SPWM technique it is clear that this signal contains much smaller harmonics, as confirmed by the harmonic content. The difference can be clearly seen with only 5 levels. This becomes more visible as the number of modules increases, reducing, and potentially removing altogether, the requirements for filters. Using as an example a MMC with 400 modules per arm.

MMC STATCOM Control Scheme

The MMC STATCOM control is based on a commonly used control scheme of 2-level voltage source converter (VSC), the MMC controller has to balance the power among the SM capacitors. In this paper, a two-control-loop scheme is proposed. One control loop is used to balance capacitor energy among three phases, and a separate control loop is used to balance capacitor voltage within each arm. The overall control scheme is given in Fig. 3

To have equal capacitor energy in three phases, a slightly different phase shift is added to the STATCOM terminal voltage when the controller transforms the voltage reference from dq frame to abc frame.

With a different power angle, the powers exchanged between each STATCOM phase with the grid are slightly different. With proper PI parameters, the control loop equalizes the capacitor energy, i.e. the capacitor voltage, among three phases. To balance the capacitor voltage within an arm, the capacitor voltages are sorted. According to the arm current direction, the SM with either the highest or the lowest capacitor voltage is selected once a switch on or off event is required by the PWM generator. The advantage of this scheme is that it has a very fast response. Also it does not add distortion to the PWMreference signal and therefore has minimum impact on the harmonic contents. However, this scheme will inject small negative sequence current to the grid due to the phase shift in its terminal voltage. When the phase shift is limited to a very small value (0.015 rad or 0.86 deg), the negative sequence component is limited to minimum.

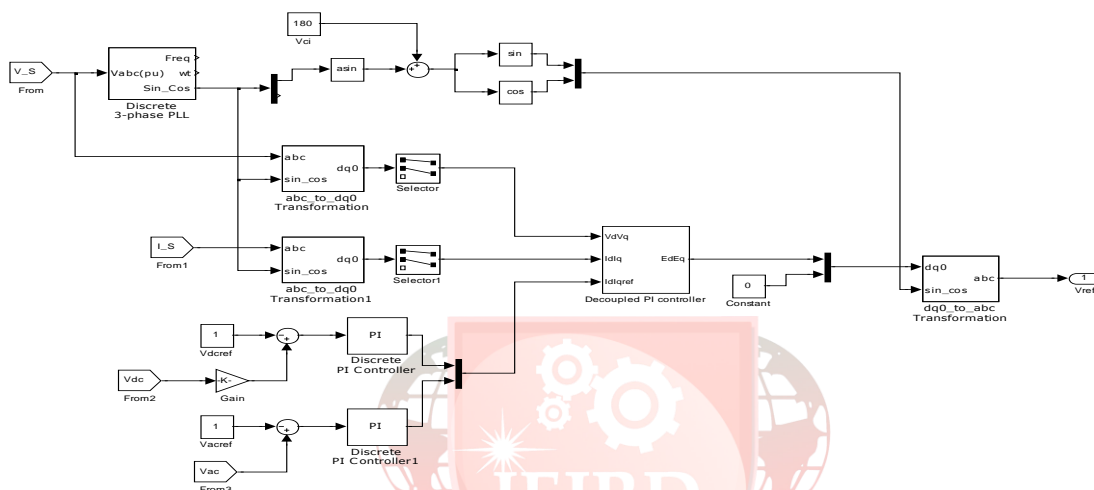

Fig.3. Implemented Control Scheme for MMC STATCOM in Project

PI Controller:

P-I controller is mainly used to eliminate the steady state error resulting from P controller. However, in terms of the speed of the response and overall stability of the system, it has a negative impact. This controller is mostly used in areas where speed of the system is not an issue. Since P-I controller has no ability to predict the future errors of the system it cannot decrease the rise time and eliminate the oscillations. If applied, any amount of I guarantees set point overshoot.

V-I Characteristics of STATCOM

A typical $V-I$ characteristic of a STATCOM is depicted in Fig.4 As can be seen, the STATCOM can supply both the capacitive and the inductive compensation and is able to independently control its output current over the rated maximum capacitive or inductive range irrespective of the amount of ac-system voltage That is, the STATCOM can provide full capacitive-reactive power at any system voltage even as low as 0.15pu. The characteristic of a STATCOM reveals strength of this technology: that it is capable of yielding the full output of capacitive generation almost independently of the system voltage (constant current output at lower voltages). This capability is particularly useful for situations in which the STATCOM is needed to support the system voltage during and after faults where voltage collapse would otherwise be a limiting factor [1,5].

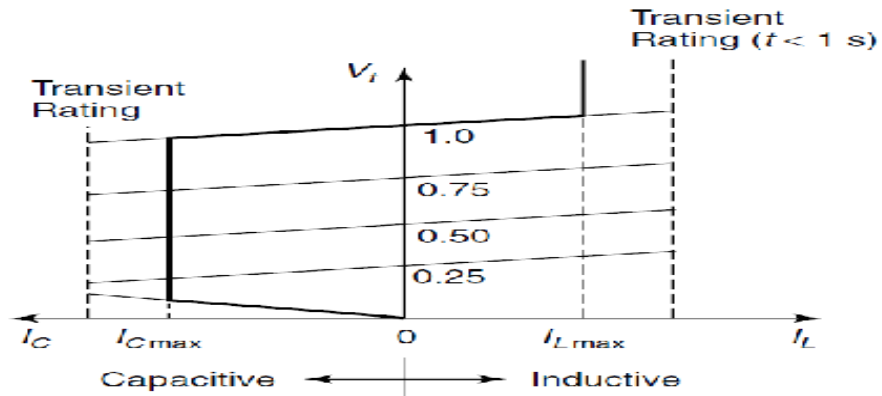

Fig. 4. The V-I characteristic of the STATCOM

RESULTS & SIMULATION

Introduction

The system is connected with 66 Kv Source voltage is studied in this paper . We used Modular multilevel converter to the STATCOM which is connected parallel to the transmission line. MMC STATCOM supplies reactive power to transmission line. Reactive power is supplied with the help of VSC which is consist of Modular Multilevel Converter circuit with IGBT's.

System is studied under three different condition

- 1) System under Steady state
- 2) System Under Sag condition
- 3) System Under Fault condition

And simulation results are discussed in detail as follows

- 1) System under Steady state

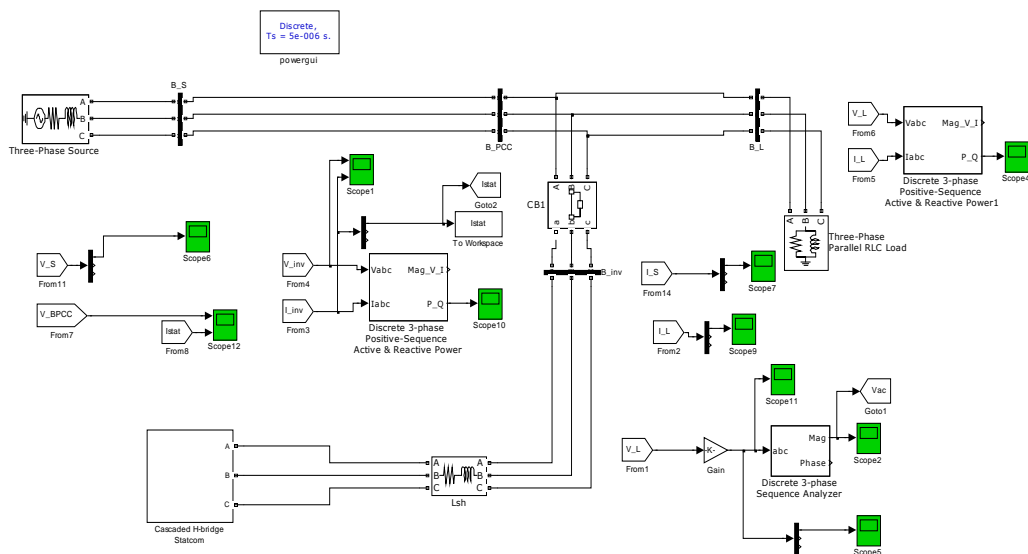

In steady state, the STATCOM performance is studied. All the voltages are well balanced and regulated. The good waveforms of voltage and STATCOM current at the PCC bus show that passive filter becomes unnecessary

Figure below shows the normal power system without any power quality problem. The source voltage and Current . PCC voltage and current ,STATCOM power ,load active and reactive power waveforms are shown below.

1.1 PCC voltage and current

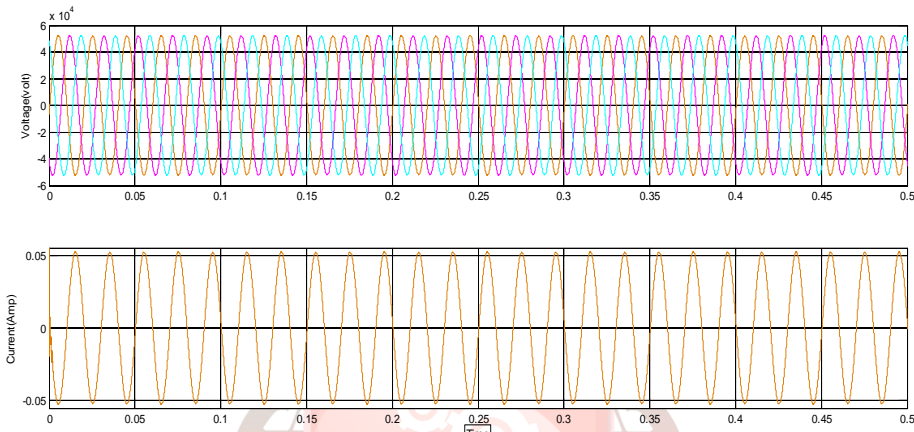

Fig:-5 Voltage and current at PCC Bus

1.2 Source voltage & Source current

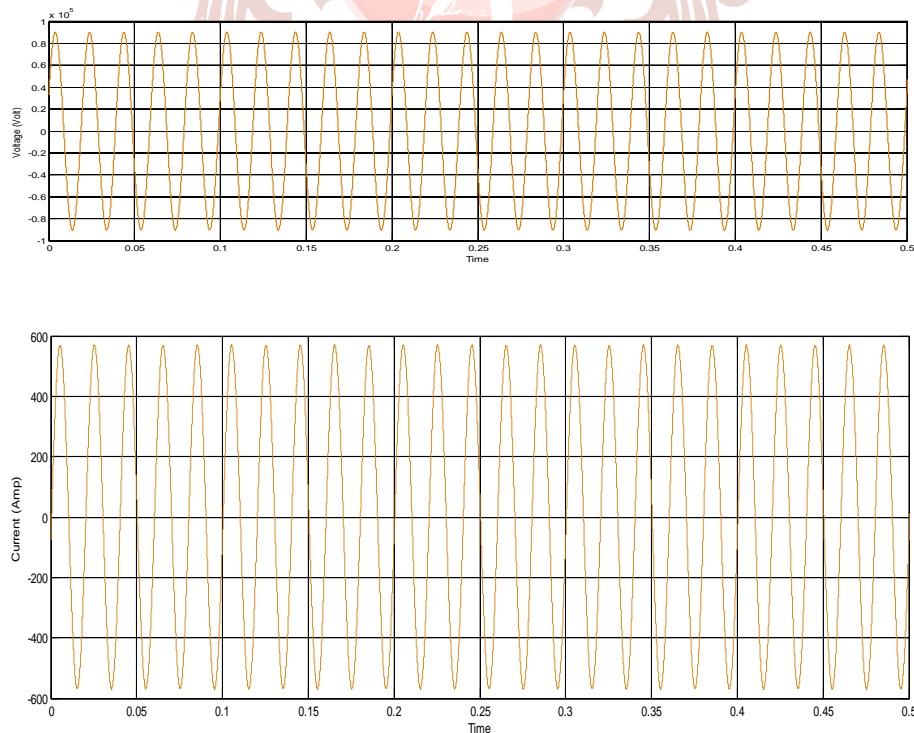

Fig:-6 Source voltage & source current under Steady state condition

1) System under Sag with STATCOM

In the System under Sag, the source bus voltage drops from 63.27 Kv to 31.63 Kv to represent heavy load conditions in the grid. The STATCOM responds to the voltage sag quickly and the PCC bus voltage restores to 63.27 Kv within 0.1 s,

Figure below shows the normal power system without any power quality problem. The source voltage and Current. PCC voltage and current, STATCOM power, load active and reactive power waveforms are shown below.

2.1 PCC voltage and current

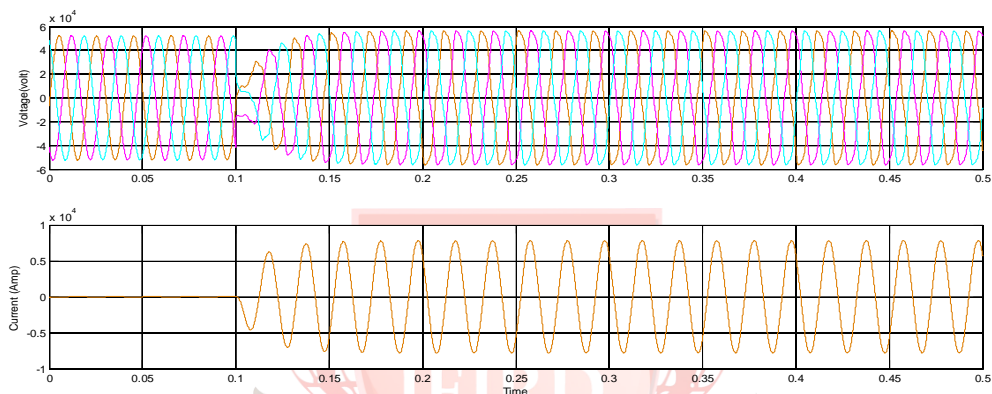

Fig:-7 PCC voltage and Current under Sag in System

2.2 Source voltage & Source current

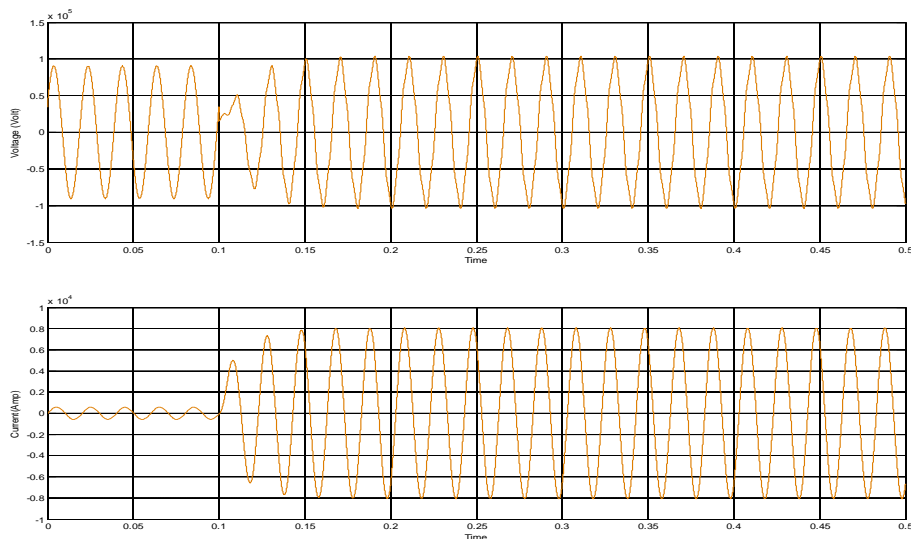

Fig:-8 Source Voltage & current under Sag condition

1) MODEL OF MODULAR MULTILEVEL CONVERTER STATCOM UNDER FAULT CONDITION

3.1.Source Voltage & Source Current Without STATCOM

Figure shows the magnitude of source voltage and current without STATCOM under fault condition in which magnitude of voltage is reduced from 63.27 KV to 31.63 Kv for sag condition from duration 0.2 sec and then decrease to 0 volt for transient fault for (0.3-0.4) sec transition period & Current magnitude rises from 510 A to 5027 A for transient fault for (0.3-0.4) sec transition period respectively.

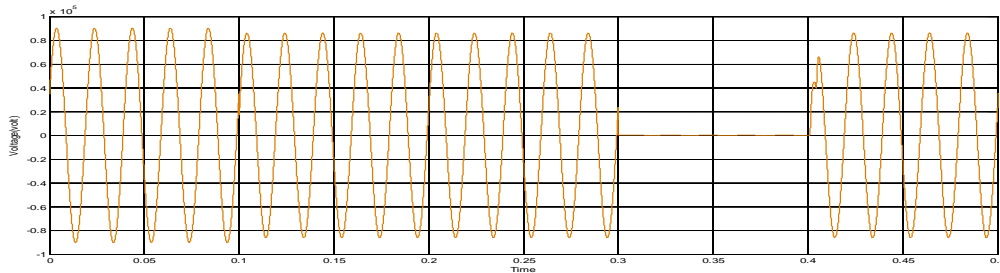

Fig:- 9.Source Voltage in Fault condition without STATCOM

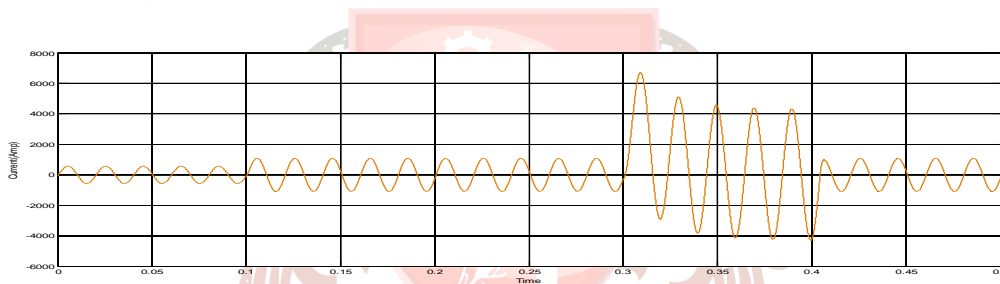

Fig:-10 Source Current in Fault condition without STATCOM

3.2.Source Voltage & Source Current With Statcom

Figure shows the magnitude of source voltage and current without STATCOM under fault condition in which magnitude of voltage is reduced from 63.27 KV to 31.63 Kv for sag condition from duration 0.2 sec and then decrease to 0 volt for transient fault for (0.3-0.4) sec transition period & Current magnitude rises from 510 A to 5027 A for transient fault for (0.3-0.4) sec transition period respectively. STATCOM inject reactive power of 82 MVAR in system to restore the voltage to normal condition

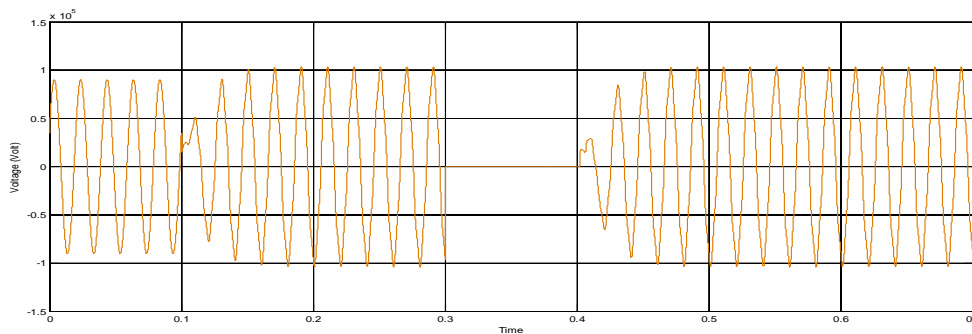

Fig:- 11.Source Voltage in Fault condition with STATCOM

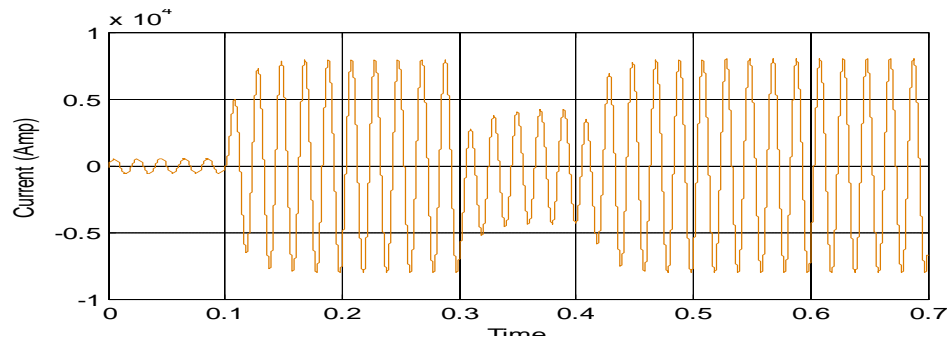

Fig:- 12 .Source Current in Fault condition with STATCOM

STATCOM voltage and current under fault condition

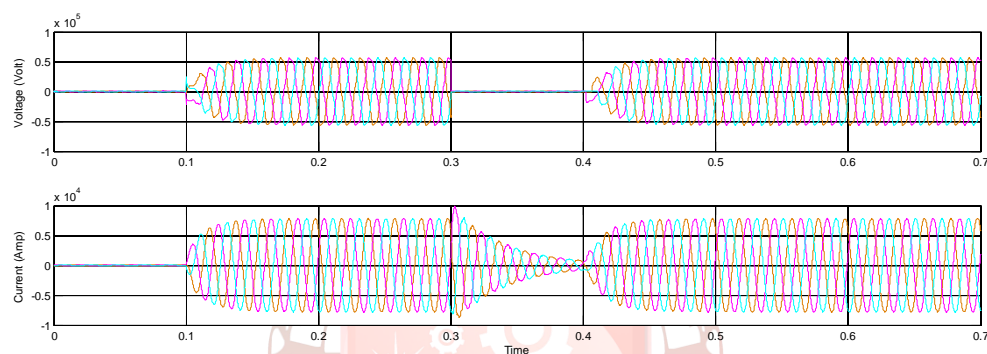

Fig:-13 STATCOM voltage and current under fault condition

Conclusion

In this paper a full-bridge modular multilevel STATCOM model is implemented and simulated. Also this paper proposed a control scheme for MMC STATCOM. In this scheme, the SM capacitor voltages are balanced by two control loops, one equalizes the capacitor energy among three phases, and the other balances the capacitor voltage within each arm. This scheme has fast response and minimum impact on the STATCOM voltage and current harmonics. The MMC STATCOM and its controller are validated in a test system for scenarios, i.e. the steady state, voltage sag, 3-phase-ground ac fault, and Results show the proposed control scheme is effective and robust. The STATCOM has fast response to voltage sag, and fast recovery after ac or dc faults, even without protections circuits.

REFERENCES

- [1] "Modular Multilevel Converter Based STATCOM Topology Suitable for Medium-Voltage Unbalanced Systems"; Hassan Mohammadi Pirouzy and Mohammad Tavakoli Bina, Journal of Power Electronics, Vol. 10, No. 5, , pp. 1534 – 1545 September 2010
- [2] "A Transformerless Medium-Voltage STATCOM Topology Based on Extended Modular Multilevel Converters"; H. Mohammadi P., *Student Member, IEEE*, and M. Tavakoli Bina, IEEE TRANSACTIONS ON POWER ELECTRONICS, VOL. 26, NO. 5, MAY 2011

- [3] “Modeling and Control of a Full-Bridge Modular Multilevel STATCOM” Wei Li, L.-A. and J. Bélanger: [Power and Energy Society General Meeting, 2012 IEEE](#) 22-26 July 2012 Page:1 – 7 ISSN : 1944-9925
- [4] “Performance and Analysis of Modular Multilevel Converter” T.Yuvaraja, Somnath Mazumder ; American Journal of Engineering Research (AJER) 2014 e-ISSN : 2320-0847 p-ISSN : 2320-0936 Volume-03, Issue-01, pp-01-08
- [5] “Modular Multilevel Converters Part-I: A Review on Topologies, Modulation, Modeling and Control Schemes” ; Sreedhar Madichetty, Abhijit Dasgupta ; International Journal of Power Electronics and Drive System (IJPEDS) Vol. 4, No. 1, March 2014 pp. 36~50 ISSN: 2088-8694
- [6] “MULTI-LEVEL INVERTER: A Literature survey on topology and control strategies”; Bindeshwar Singh , Nupur Mittal, DR. K.S.Verma, DR. Deepika Singh; International Journal of Reviews in Computing 31st July 2012. Vol. 10 © 2009 - 2012 IJRIC & LLS. ISSN: 2076-3328; E-ISSN: 2076-3336
- [7] “New transformerless STATCOM topology for compensating unbalanced medium-voltage loads,” H. M. Pirouz and M. T. Bina, in *Proc. 13th Eur.Conf. Pow. Electron. Appl.*, Barcelona, Spain, Sep. 2009, pp. 1–9.
- [8] “Phase-shifted carrier PWM technique for general cascaded inverters,” R. Naderi and A. Rahmati, IEEE Trans. Pow. Electron., vol. 23, no. 3,pp. 1257–1269, May 2008.
- [9] “Control and Performance of a Modular Multilevel Converter System,” CIGRÉ Canada, Wei Li, Luc-André Gregoire, Jean Bélanger, Conference on Power Systems, Halifax, Sept., 2011, 8 pp.
- [10] “Phase-shifted carrier PWM technique for general cascaded inverters,” R. Naderi and A. Rahmati, IEEE Trans. Pow. Electron., vol. 23, no. 3,pp. 1257–1269, May 2008.

E-ISSN NO:2349-0721