



## MULTIPURPOSE CULTIVATION VEHICLE WITH MECHANICAL ADVANTAGE (SEED SOWING MACHINE)

<sup>1</sup>Kore Nagesh Ramesh, <sup>2</sup>Lavate Suraj Appasha, <sup>3</sup>Tanveer Ahamad Nijam, <sup>4</sup>Paramshetti S. C  
S.V.S.M.D's K.K.I. Polytechnic, Akkalkot<sup>1,2,3</sup>, Lecturer in Mechanical Engg. Department S.V.S.M.D's  
K.K.I. Polytechnic, Akkalkot<sup>4</sup>

### ABSTRACT

As we know agriculture is the backbone of India. Rice and Wheat is one of the new targets in agriculture where still, less researchers and manufacturers participate. This field faces some problems such as how to minimize the losses, how to increase productivity and how to minimize cost. In India, two types of agricultural methods are used, manual method (conventional method) and mechanize type method. Mechanization involves the use of a hybrid device between the power source and the work. This hybrid device usually transfers motion, such as rotary to linear, or provides ample of mechanical advantages such as increase or decrease or leverage of velocity. Agricultural machinery is machinery used in farming or other agriculture. Mechanized agriculture is a process of using agricultural machinery to mechanize the work of agriculture, greatly increasing farm worker productivity. In this modern era, automated agro machinery has replaced many farm jobs that are carried out by labour or by animals such as oxen, horses etc.. The entire history of agriculture contains many examples of the use of tools, such as the hoe and the plough. The benefit of agro automation is that it saves the labour cost. However, it also saves the energy and cost of materials and to improve the quality, accuracy, and nicety. The seed feeding, pesticides sprinkling and crop cutting are the important stages in the agriculture field. The design of multipurpose agro equipment machine will help Indian farmers in rural side and small farm. It will reduce the cost of seed feeding, pesticides sprinkling and crop cutting the field and will help to increase economic standard of an Indian farmer.

**Keywords:** Ploughing, digging, seed sowing, fertilizer pouring, soil covering.

### INTRODUCTION

Agriculture being one of the major occupation in India, it is very essential to discover and implement new idea in this field, though lot of work has been done in this area. It is observed that, these ideas are not been implemented properly in actual agricultural field. This is due to more cost and is daedal for rural people. Multipurpose agriculture equipment is basic and major equipment involved in agriculture for maximum yielding. Conventional method of planting and cultivating the sugarcane is a laborious process and hence for that reason there is a scarcity of labours, this result in delayed agriculture to overcome these difficulties, multipurpose agriculture equipment is designed. Agriculture plays a vital role in the Indian economy. Over 70 % of the rural households depend on agriculture. Agriculture is an important sector of Indian economy as it contributes about 8.4% to the total GDP and provides employment to over 60% of the population. Indian agriculture has registered eloquent addition to over last few decades.

Agriculture is the backbone of India. The agricultural history in India dates back to Indus Valley Civilization Era. Today, India ranks second worldwide in farm output. The special vehicles plays a major role in

various fields such as industrial, medical, military applications etc., The special vehicle field are gradually increasing its productivity in agriculture field. Some of the major problems in the Indian agricultural are rising of input costs, availability of skilled labors, lack of water resources and crop monitoring. To overcome such adversity, the automation technologies were used in agriculture. The automation in the agriculture could help farmers to reduce their efforts. The vehicles are being developed for the processes for ploughing, seed sowing, leveling, water spraying. All of these functions have not yet performed using a single vehicle . In this the robots are developed to concentrate in an efficient manner and also it is expected to perform the operations autonomously. The proposed idea implements the vehicle to perform the functions such as ploughing, seed sowing, mud leveling, water spraying. These functions can be integrated into a single vehicle and then performed.

## LITERATURE SURVEY

1. D.A. Mada, Mahai, [2013], In this research paper author has mentioned the magnitude of automation in agricultural field by giving some instance. The conclusion from the paper was need of multifunctional vehicle for pre and post harvesting. We have taken this as base of our research and take further changes in production of our multipurpose agricultural vehicle.
2. V.K. Tewari, A. Ashok Kumar, SatyaPrakash Kumar, BrajeshNare[2012] In this research papers author have done case study on farm mechanization in west Bengal as being part of India it give clear status about availability and progress in India. This ensured us to take right steps compared to current steps.
3. F.A. Adamu, B. G. Jahun and B. Babangida [2014]In this paper authors draws our attention towards the performance factor of a power tiller.Among those demand for light weight power tiller was sought out most.Fuel efficiency and field capacity such parameters are also discussed. We taken those points in consideration while designing a sustainable multifunctional agricultural vehicle

## WORKING PRINCIPLE

A India is a country where farming is main occupation and culture then also in India most of farmers attempt suicide reason behind this is machine , as in India 10-20% of farmers are rich but rest of farmers don't have much source to purchase heavy equipment and machines. So we have decided to design a agricultural vehicle which can satisfies the basic need of farming and cost of agricultural vehicle should be very less as compared to other agricultural vehicle. The main objective of agricultural vehicle is drilling, fertilizer spraying, seed sowing & ploughing.

For solving this purpose we have designed this type of agricultural vehicle

- When engine is started the auger bit drill tool will activated to drill hole for seed sowing after that operator press lever for drop a seed from hopper then the digging and sowing operation will be completed. The sowing operation can be done by semi manual.
- Ploughing tool is easily assemble and dissemble, This operation is done by the manual force.

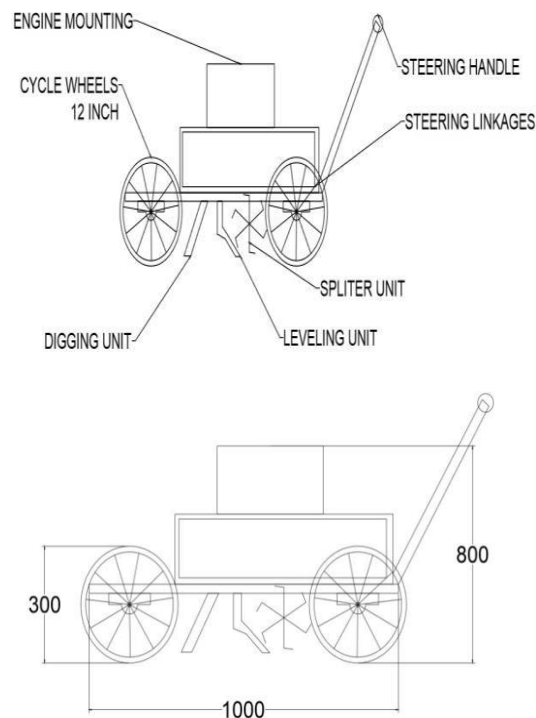

Concept diagram Multipurpose agriculture Vehicle

## COMPONENTS OF SYSTEM

### Engine:

The 100cc Engine is mounted on front of the chassis, it is used for digging operation.

- The auger bit drill tool connected to the engine for dig a hole.
- The speed of engine can be increased or decreased by the accelerator which is given near to the handle

### Ploughing:

The primary purpose of ploughing is to turn over the upper layer of the soil, bringing fresh nutrients to the surface, while burying weeds and the remains of previous crops and allowing them to break down. As the plough is drawn through the soil it creates long trenches of fertile soil called furrows. In modern use, a ploughed field is typically left to dry out, and is then harrowed before planting. Ploughing and cultivating a soil homogenises and modifies the upper 12 to 25 cm of the soil to form a plough layer. In many soils, the majority of fine plant feeder roots can be found in the topsoil or plough layer.

### Leveling:

A Sheet metal Plate is used as mud closer and leveler, The long bolt and nut is used for leveler up & down movement. The Leveler is not powered, instead it is fixed to required level initially, The leveler closes the soil in the sowed soil & levels the land

### Seed Sowing:

The A ladle is used for Seed storage, We have provided hole to the hallow cylinder which is coupled to the DC motor shaft, where the funnel is placed above it, The DC motor is powered by a battery which is controlled using a toggle switch, As the motor is switched on, the hallow cylinder tend to rotate which makes the seeds fall on the cultivated field making consistent gap between seeds. Rotary motion of motor provided to the

sowing shaft (which will placed in seed storage tank) by chain drive. Due to this shaft will rotates and it drop the seed from hopeer to the digger through the hose for digging purpose. For one revolution of shaft only one seed is required to deposit this function can be fulfill by using bush.

#### **Digging:**

The digger mechanism is used for digging and seeding. Digger itself is used as digging tool. Digger is connected to the frame by nut bolt. There are three adjustable diggers. Diggers has a flapper for opening into the cavity for seeding. Flapper is connected to the hopper with the help of hose.

### **FEATURES OF VEHICLE**

1. Multipurpose, can perform cultivations operations such as ploughing, cloud breaking, sowing, fertilizing, leveling, weeding, weedicide application.
2. Multitasking, in one assembly of the equipment it performs sowing, fertilizing and leveling. In another assembly it performs weeding and weedicide application.
3. Automated, the equipment can be animal powered or tractor powered just pulling of the equipment is enough and rest of the actions are automated.
4. The Successful implement of scientific farming with our equipment will lead to higher yield and better quality of crop.
5. Applicable for all type of seed to seed cultivation.
6. Sequential spacing of seeds will reduce the wastage of seeds and helps in the best utilization of the field and reduces the thinning and filling effort.
7. Number of workers required is reduced excessively, which in turn reduces labor charges.
8. Variable with dimensions and farming specifications
9. Adopted scientific farming and Precision forming technology.
10. Our equipment is completely flexible for easy assembly and disassembly.

### **SCOPE FOR FUTURE WORK**

By increasing the equipment strength and quality to its peak, we can have multipurpose agricultural equipment for life time usage. By providing hydraulics, gear arrangements and some minor adjustments the equipment can also be made as tractor powered equipment.

### **CONCLUSIONS**

Practically our multipurpose agricultural equipment can be used for tilling, fertilizing, sowing, leveling and also used for weed removal purposes. All the parts are connected in such a way that in every stage of agriculture the equipment can be rearranged or easily assembled with fasteners to required length and specifications of field operation. Our team has successfully combined many ideas from various fields of mechanical engineering and agricultural knowledge to improve the yield and by reducing the labor effort and expenses. The whole idea of multipurpose equipment is a new concept, patentable and can be successfully implement in real life situations.

### **REFERENCES**

1. R. Sadiq, S. Gopalakrishna, "Design and fabrication of multipurpose agricultural equipment", International Journal of Advances in Production and Mechanical Engineering, 1, (2015), 38-45.

2. Kannan, K. Esakkiraja, "Design modifications in multipurpose sowing machine", International Journal of Research in Aeronautical and Mechanical Engineering,2,(2014),35-40.
3. D. Ramesh, H. Girishkumar, "Agriculture seed sowing equipments: A review international journal of science", Engineering and Technology,( 2014) 1987- 1992.
4. T. Sambouli, N. Zapata, "Performance of new agricultural impact sprinkler fitted with plastic nozzles", Biosystems Engineering,118,(2014),39-51.
5. P. Vijay, K. Rakesh, "Design of a multi-purpose seed sower cum plougher", International Journal of Emerging Technology and Advanced Engineering,3,(2013),1-8.
6. K. Hao, Z. Ripin, "Nodal control of grass trimmer handle vibration", International Journal of Industrial Ergonomics,43,(2013),18-30.
7. Girish, S. Satyavath, "Design and fabrication of multipurpose farm equipment" ,Automotive and Aeronotical Engineering,1,(2012),0-1.

