

METHODS OF CONTROL OF AIR PRESSURE IN THE WORKING CHAMBER OF ARRALI DEMON MACHINE

¹Sh. Khusanova, ²S. Esonzoda, ³B. Mirzayev, ⁴I. Khakimov

Senior lecturer at Fergana Polytechnic Institute¹, Assistants of Fergana Polytechnic Institute^{2,3}, Student of Fergana Polytechnic Institute⁴.

Iqboljon.Xakimov.95@Mail.Ru

ANNOTATION

In the 21st century of technology, millions of new innovations are being created in every field. At the same time, a lot of research is being carried out in the cotton industry of Uzbekistan. The project we are proposing is also aimed at automating the cotton industry and controlling the air pressure in an island gin machine. The main purpose of this is to increase the efficiency and quality of fiber separation from seeds.

Keywords: *Arrali gin machine, working chamber, automation, air duct, pressure.*

The seed cotton is cleaned in the plant's cleaning department, and the main production is pulled into the building by a separator through a pneumatic pipe and fed to the distribution auger. The distribution auger throws the seed cotton into the mine mounted on the supplier and then feeds it to the supply equipment.

The main function of the gin-mounted supplier is to deliver the seeded cotton to the gin's working chamber in a finely ground manner.

The technological scheme of the PD gin supply equipment is shown in Figure 1, and the kinematic scheme is shown in Figure 1. The process is as follows: the seed cotton falls into the mine, which is located on the supplier. Opposite rotating supply rollers (1) take the seed cotton evenly from the mine and transfer it to the pile drum (2), which drives the cotton over the mesh surface (3) and finely grinds the seed cotton. It clears the ps one last time. The cleaned seed is passed to the rod (4) using a cotton pile drum and dropped into the working chamber of the gin. The separated dirt is removed from the equipment by means of a belt conveyor (5).

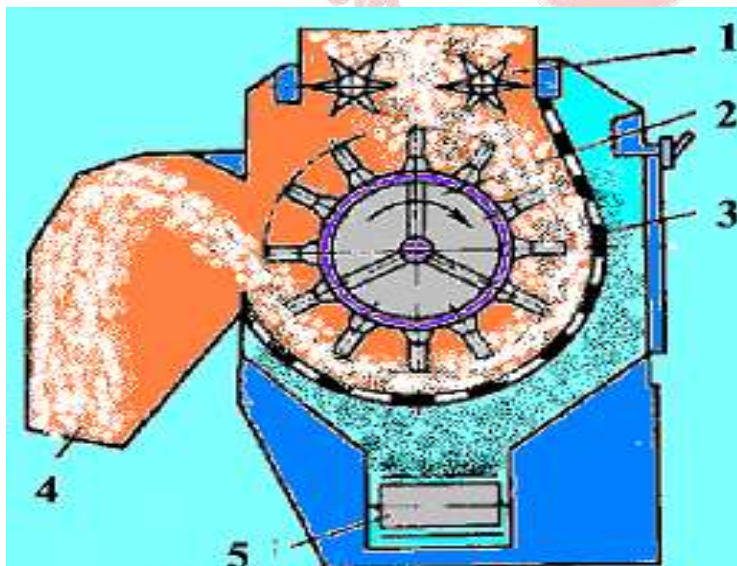

Figure 1. PD supply equipment

1. Supplier Value;
2. Pile drum;
3. Mesh surface (surface);
4. Nov (tray);
5. Pollution conveyor belt;

Due to the fact that the rotation speed of the supply rollers (1) is adjusted by means of a pulse variator type IVA mounted on the axis of this roller, the volume of seed cotton transmitted to the working chamber of the gin can be more or less, i.e. creates an opportunity. 3XDDM, DP-130, 4DP-130, 5DP-130 and DPZ-180 saw blades are used to separate the medium fiber cotton fiber from the seed. It processes all industrial varieties of medium-fiber cotton with a moisture content of 7 ÷ 9% and industrial varieties IV and V of long-fiber cotton.

The construction of saw demons consists of the following working bodies, parts:

- working chamber (apron, seed comb, roof beam);
- grate grate;
- saw cylinder;
- a device for separating the fiber from the saw teeth;
- corpse separating the corpse;
- pollution conveyor;
- base made of cast iron walls (stanina).

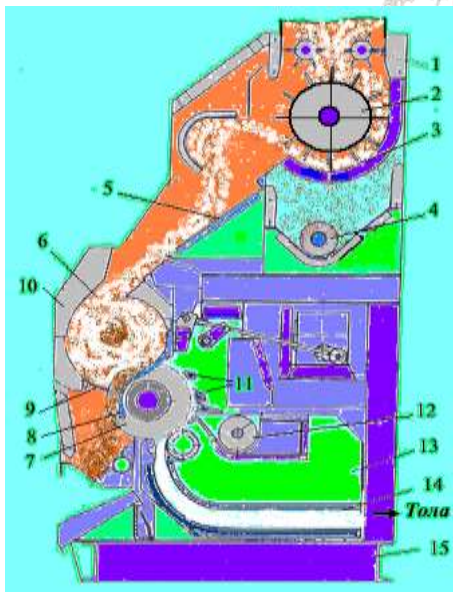

Figure 2. 5 Cross-section of DP-130 gin

1. Supply rollers; 2. Pile drum; 3. Grid surface; 4. Dirty shnegi; 5. Nov; 6. Working camera; 7. Arrali cylinder; 8 Kolosnik; 9. Seed comb; 10. Front apron; 11. Colossal grille; 12. Waste transfer screw; 13. Air chamber; 14. Fiber transmission line; 15.Rama (basis);

The operation of the 5DP-130 saw blade (Fig. 2) is as follows: The supply drum grinds the cotton (2) to remove the fine impurities and gives the required amount of gin. In it, the cotton falls into the working chamber (6) to form the raw material roller and picks up the fiber with the saw teeth of the saw cylinder (7) and passes it through the gap of the chisel (8). Because the spacing of the columns is smaller than the size of the seed, only the fiber passes through. The fiber in the saw tooth is separated from the tooth by means of the air coming out of the hole of the air chamber (13) behind the coil and delivered to the next process through the transmission pipe (14). When the fiber passes behind the grate, it is cleaned of debris by hitting the blade (11) mounted on the back of the saw, and they are removed from the machine by falling on the screw conveyor (15, 16).

In our project, the aim is to control the air pressure in the working chamber of the saw blade machine. This leads to a decrease in the quality of fiber and seed. If the required amount of seed cotton is delivered, depending on the pressure level in the working chamber, the process of separating fiber from seed is normalized. To carry out this process, you must first use IT. First, let's get acquainted with programming.

Programming is divided into direct programming and automatic programming. In direct programming, the programmer does everything from developing the overall layout of the program to encoding and entering it into the machine. In automatic programming, the programmer simply creates a program diagram and writes it in abbreviated symbolic form, while the technical work, such as creating a profile and encoding it, is performed by the machine itself using a special programming program.

Typically, programming is done using high-level programming languages (Delphi, Java, C ++, Python). Because the semantics of these programming languages are close to human language, the programming process is much easier. Programming is the process of creating, testing, and modifying software for computers and other microprocessor-based electronic machines. One of the most efficient microprocessors today is the Arduino, a breakthrough in robotics.

An Arduino is a small board that has its own processor (microcontroller) and memory.

There are many types of Arduino, for example: Arduino Yun, Arduino Uno, Arduino Duemilanove, Arduino Diecimila, Arduino Nano, Arduino Mega, Mega 2560, Mega ADK, Arduino Leonardo, Arduino Micro and so on. An application that is small and large on this device can perform various devices, robots, and operations by creating algorithms. In other words, an Arduino is a device that combines software and hardware. As mentioned above, there are many types of Arduino, and the study of Arduino mainly uses the Uno or Nano type of Arduino. The difference from other types of Arduino Uno is the processor, microcontrollers, more or less digital and analog outputs. The user of the Arduino will be able to connect to it various electrical components and modules, for example: LED lights, sensors, relay modules network (Wi-fi, Bluetooth, Ethernet) modules, sensors, motors, magnetic door locks and powered by electricity all things. As mentioned above, the Arduino is a device that combines the technical and software part. Programs for Arduino are written in the usual C ++, simple and clear algorithms and programs are created to control I / O (Input-Input, Output-Output) in the contacts. Arduino also has an Arduino IDE (Arduino software, compiler) running on Windows, Mac OS and Linux operating systems for writing programs. Creating algorithms and programs in the Arduino IDE program is very easy and easy to operate. (Figure 3)

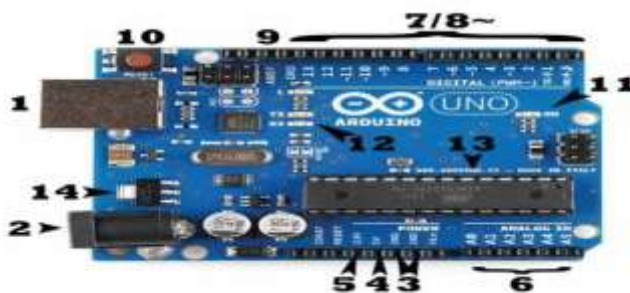

Technical specifications of Arduino Uno: Microcontroller: ATmega328; Operating voltage: 5 V; Input voltage (recommended): 7-12 V; Input voltage (maximum): 6-20 V; Digital input / output: 14 (6 of them can be used as KIM (Shirotno Impulsnaya modulation)); Analog input: 6; AC current through input / output: 40 mA; 3.3 V AC input: 50 mA;

Flash memory: 32 KB (ATmega328) is used as a 0.5 KB bootloader; RAM: 2 KB (ATmega328); EEPROM: 1 KB (ATmega328); Frequency: 16 MHz;

Let's look at how to determine the air pressure in the working chamber of a demon using an Arduino device.

In this case, the Arduino device is the motherboard. Special software codes are developed to determine the pressure on the Arduino device. The developed code. The USB cable is placed from the computer to the Arduino device. In addition, we need additional equipment to perform this process. One of the most important devices is the display. The display is a device designed to display text or graphic data on the screen of an electronic device. For this we use the I2C LCD display. To connect this display to the Arduino device from SDA, SCL, GND, VCC pins (Figure 3).

Special sensors are used to detect the air pressure in the working chamber of the saw blade. One of these sensors is the PSI Pressure sensor, which is used to measure pressure using this device. Vdd, GND and output pins are used to connect the Arduino board to the PSI Pressure sensor (Figure 3).

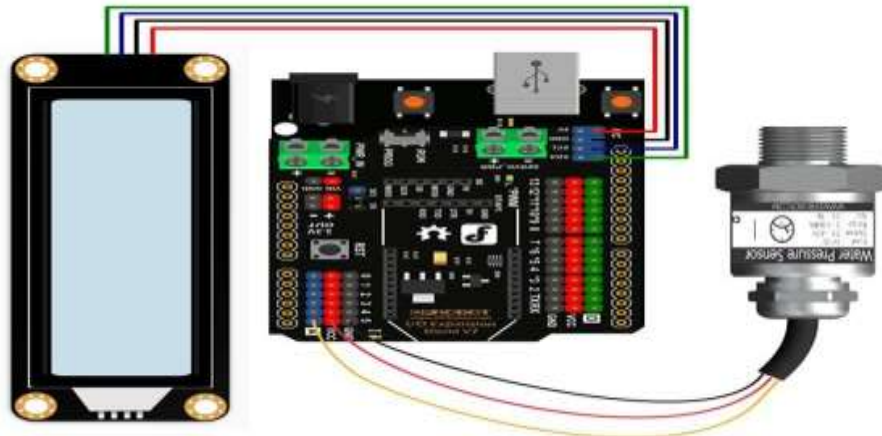

Figure 4. Wiring diagram of I2C LCD display and PSI Pressure sensor with Arduino device

The PSI Pressure sensor is placed in the working chamber of the Arrali gin machine according to the scheme shown in Figure 4. The Arduino device is placed next to the arrali gin machine with a special body. Then the result can be seen on the Lcd display. The installed shaft is automatically transferred to the seed cotton supplier depending on the air pressure in the working chamber. opens and transfers the seeded cotton to the supplier in the desired shape. (Figure 5).

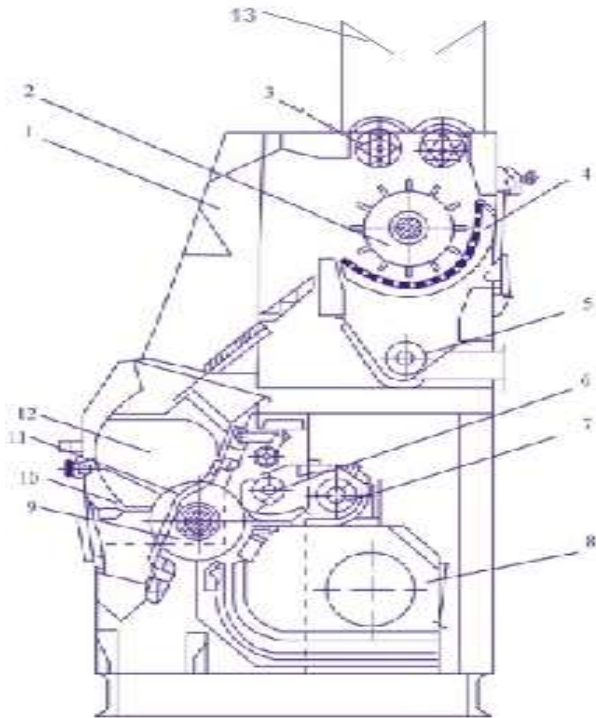

Figure 5. 5 Cross-section of DP-130 gin

1.PD provider; 2. Pile drum; 3. Supply roller; 4. Grid surface; 5. Waste collection chamber; 6.Dry; 7. Ulyuk conveyor; 8 Air chamber; 9.Arrali cylinder; 10. Seed comb; 11. Colossal grille; 12. Working chamber 13. Automated mine

This is the first stage of Arrali Jin machine programming, and further research is planned to implement other directions of Arrali Jin machine programming. Given the wide range of capabilities of Arduino device. It should be noted that.

REFERENCES

1. Jabborov G'.J. etc. "Technology of seed cotton processing", Textbook. Tashkent - "Teacher" 1987
2. Shaykhov ET and others "Cotton", Tashkent "Labor" - 1990.
3. Bobojonov M.A. Text of the report "Design of technological processes". Tashkent, TTESI, 2008.
4. Tillaev M.T. Lecture course on the theoretical foundations of the technology of primary processing of cotton from the part of cotton ginning and seed linting. T. TTESI, 2009
5. Hojiev MT, Mardonov BM, Sirojiddinov FN. Textbook on "Modeling of technological processes in the cotton industry." Tashkent, "Sparks of Literature", 2018, 333 p.