



## DESIGN AND FABRICATION OF COTTON PICKER MACHINE

Gajanan Wadekar<sup>1</sup> Masnaji Akkulwar<sup>2</sup>

Student Mechanical Engineering Department, Suresh Deshmukh College of Engg,  
Selukate, Wardha , Maharashtra, India

<sup>1</sup> Gajananwadekar7@gmail.com

### ABSTRACT—

*This work will give a new technology in the field of cotton boll picking mechanism and to develop machine which is low weight ergonomically which could be used to pick cotton bolls. In India entire cotton is handpick by labor, internationally available machine for cotton boll picking is costlier and its shows that due to spindle type cotton picking machine, percentage of short fiber content increases result in poor quality of cotton fiber strength. Suction type cotton boll picking machine will give new technology in the field of agriculture, which is helpful for Indian farmer, it is not costly and easy to handle. Farmer can easily use suction type cotton-picking machine.*

*Index Terms—Component, formatting, style, styling, insert.*

*Keywords: Cotton Ball; Mechanism; Spindle; Fibre*

### INTRODUCTION

Cotton, the most important commercial crop playing a key role in economic and social affairs of the world continues to be acclaimed as 'king fibre'. It is the oldest among the commercial crops of the world. The culture and history of

India is intimately related at all periods with the growth of cotton and cotton textiles. The British Empire, for over a century, from 1840 AD made a big fortune on Indian cotton, available, to it as the cheapest raw material for its world encompassing textile industry. Among the fibre crops, cotton provides about 80 per cent of the raw materials for the manufacture of textile in the country. Today cotton is the number one agricultural commodity, sustaining Indian economy with export earnings worth Rs.35872 cores. Cotton picking is one of the major labor intensive operations in cotton cultivation consuming the lion's share of the expenditure. Since the varieties used in our country require cotton picking at several stages, the use of mechanical cotton pickers is not feasible as in the case of defoliated picking method. Hence the only option is the selective picking method. It is very hard to realize a mechanically operated selective picker. Therefore, a pneumatic cotton picker was developed.



Fig1: Manual Picking of Cotton

#### **literature review**

1. "Design & Analysis of Cotton Picking Machine in View of Cotton Fibre Strength" by Nikhil Gedam; Prof.A.K.Mahallein International Journal of Engineering Research and General Science Volume 3, Issue 3, May-June, 2015

It investigates that Spindle - type cotton picking machine, is one of the cotton picking machine which remove the cotton from open bolls .The spindles, which rotate on their axes at a high speed, are attached to a drum that also turns, causing the spindles to enter the plant. The cotton fiber is wrapped around the moistened spindles and then taken off by a special device called the doffer, from which the cotton is delivered to a large basket carried above the machine. During wrapping of cotton fiber around the spindles bars, fiber stretched will result in increased short fiber content and trash and hence loses fiber quality and strength. Therefore, there is an urgent need to develop such a system, which helps to Indian framer.

2. "Performance evaluation of a manually operated cotton picker" Adebija J. A, and Jackson B. A. in African journal of agricultural research, vol. 8(29), pp. 3883-3887, 1 august 2013

It investigate that the manually operated cotton picker can be improved for greater efficiency, increase in field capacity and speed of picking using

a fuel (petrol or diesel) powered engine. Improvement can be made in the picking width by increasing the picking fingers in such a way that two rows can be picked at a time. With this improvement a specific planting space and ridge spacing will have to be used on the field. All these will reduce total time needed to work on a field and the man-ha-hour-1 value of the machine. Speed of picking will also be enhanced if a fuel (petrol or diesel) powered engine replaces manual operation.

3. "The Effect of Harvesting Procedures on Fiber and Yarn Quality of Ultra-Narrow-Row Cotton" David D. McAlister III, Clarence D. Rogers The Journal of Cotton Science 9:15–23 (2005)

The purpose of this study was to evaluate the impact of harvesting method on the spinning mill performance and quality of rotor-spun yarns made from cotton grown in ultra-narrow rows. Although it is not practical to use a spindle harvester designed to pick cotton from wider row spacing to harvest cottons planted in 19.05 cm rows, if it were possible to design the spindle harvester to pick narrow row cotton it would provide an advantage to the producer in improved quality. It is useful to investigate the need for a better harvesting technology for UNR cotton or a modified planting arrangement for UNR based on the resultant fiber properties and textile performance and quality.

4. "Evaluation of Portable Cotton Picker" AmbatiRavinderRaju, GautamMajumdar, International Journal of Agriculture Innovations and Research Volume 2, Issue 1, ISSN (Online) 2319-1473.

It investigates on portable cotton picker can improve cotton harvesting efficiency without defoliation. They were more suitable for family labour in rain fed cotton harvesting with lower trash content. Participatory ergonomic evaluation

of cotton harvesting in rain fed and irrigated cotton of central India during 2012 found present contract manual harvesting is 30% more efficient than battery powered portable cotton picker. Higher load on contract laborer's heart was noticed with higher output of seed cotton regardless of methods of harvesting. Portable cotton pickers are high speed, precise and no need of defoliation but adequate training and willingness to adopt the machine is must. Adequately trained female and male pickers can pick 80 and 41% more seed cotton and 44% more cotton area was picked with Portable cotton picker. Portable cotton picker are more suitable for family labour of rain fed cotton harvesting with lower moisture percentage. Higher moisture content in irrigated cotton may be a hindrance for machine picking with frequent slippage. Trash content can be similar to hand harvesting (1- 2%). Present Portable cotton picker were frequently trouble shooting with improper cable connections, entry of burs and leaves with obstruction of over grown braches.

5. "Expert System Design for Cotton Harvesting Using Shape and Fractal Features" Mahua Bhattacharya, Medhabi Verma, Vivek Shukla, S.S. Kohli, P Rajan. CSIR CMERI Centre of Excellence for Farm Machinery. In present work authors have proposed methods based on machine vision for cotton boll plucking systems. We have used shape based features and also have used fractal features to study the level of maturity of the cotton ball to take a computer controlled decision to drive an electromechanical system. This will finally provide an expert system to find the decision regarding the maturity of the cotton ball. Based on this decision an electro mechanical system will be designed to perform the task of cotton boll picking.

### III. working principle

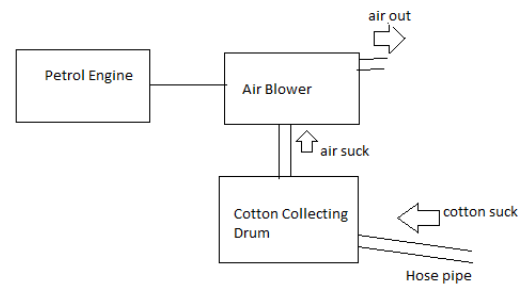

Fig2: Working Principle

Pulley connected to the shaft of engine will drives the rotor and by its rotation magnetic field generates current in primary and secondary circuit induces magnetic flux in armature change in magnetic flux by breaker point produce 170 volts in primary circuits and induces 10000 volts in secondary circuit firing spark plug .Spark plug ignites air-fuel mixture inside cylinder by high voltage in gap between centre and electrodes, moves the piston inside cylinder will rotates the cam shaft. This cam shaft rotates the impeller at high speed developed a required air suction pressure which can easily suck cotton from plant by suction hose and collected in collecting tank.

### iii. DESIGN CALCULATION

A Normal Cotton ball can be plucked by pneumatic force of 3.5N, with discharge of 0.04 m<sup>3</sup>/sec, at velocity 12.73 m/sec\*. For to produce this force we select engine power 0.70kw, speed 5600 rpm, which is connected with impeller to produce force to collect cotton from cotton ball.

#### 1. Design of Shaft:-(Ds)

Engine power=0.70kw

Speed=5600 rpm

$$\text{Power} = 2\pi NT / 60 \times KI \quad (\text{from design data book})$$

data book)

Where KI= load factor from table XI-5

$$KI = 1.25$$

$$T = 0.9549 \text{ N-m}$$

$$T = 0.9549 \times 10^3 \text{ N-mm}$$

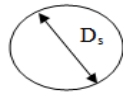

Fig.3: Shaft

Shaft Material,

SAE=1030

$S_{ut} = 527 \text{ MPa}$ ,  $S_{yc} = 183 \text{ MPa}$  (from design data book)

data book)

Factor of safety =  $S_{ut} / S_{yt}$

$$FOS = 2.83$$

$$FOS \cong 3$$

Yield strength  $S_y = 296 \text{ MPa}$  (from design data book)

data book)

Yield strength in shear  $\tau_y = 1/2 \times S_y$

$$\tau_y = 148 \text{ MPa}$$

Allowable shear stress  $\tau_a = \tau_y / FOS$

$$\tau_a = 148 / 3$$

$$\tau = 49.33 \text{ N/mm}^2$$

$$T = \pi / 16 \times \tau \times D_s^3$$

$$D_s = 4.62 \text{ mm}$$

Increased by 50%

$$D_s = 4.62 \times 1.5 \text{ mm}$$

$$D_s = 6.93 \text{ mm}$$

$$D_s = 8$$

(from design data book)

data book)

## 2. DESIGN OF IMPELLER

The diameter of the impeller eye,  $D_o$ , is dependent on the shaft diameter,  $D_s$ , which must initially be approximate. The hub diameter,  $D_H$ , is made 5/16 to 1/2 inch larger than  $D_s$ . After estimating  $D_s$  and  $D_H$ ,  $D_o$  is based on the known flow rate. The inlet vane diameter,  $D_1$ , made about the same as  $D_o$  to ensure smooth flow.

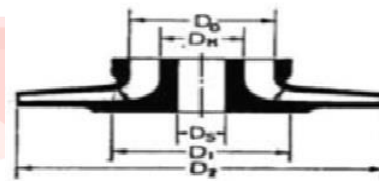

Fig.4: Impeller

The hub diameter,  $D_H$ , is made from 5/16 to 1/2 inch. larger than  $D_s$

$$D_H = 5/16 \text{ ds} + \text{ds}$$

$$D_H = 10.5$$

$$D_H = 12 \text{ mm}$$

Now,

Selected impeller of discharge  $0.04 \text{ m}^3/\text{s}$

Required discharge is  $0.25 \text{ m}^3/\text{s}$ , with velocity of  $12.73 \text{ m/s}$ .

$$V_{sp} = V_0 = 12.73 \text{ m/s}$$

The hub diameter,  $D_H$ , is made from 5/16 to 1/2 inch. larger than  $D_s$ .

$$D_H = 10.5$$

$$D_H = 12 \text{ mm}$$

Now,

Selected impeller of discharge  $0.04\text{m}^3/\text{s}$

$$U_1 = \frac{\pi \times D_1 \times N}{60 \times 1000}$$

Required discharge is  $0.25\text{m}^3/\text{s}$ , with velocity of  $12.73\text{m/s}$ .

$$U_1 = 20.52\text{m/s}$$

$$V_{sp} = V_0 = 12.73\text{m/s}$$

Inlet angle is usually  $100-200$

$$Q = \frac{V_{sp} \times \pi \times D_{sp}^2}{4}$$

As per the impeller vane blade inlet angle is  $\theta = 130$  (vane angle at inlet)

$$D_{sp} = 0.050\text{m}$$

$$\tan \theta = \frac{V_{f1}}{U_1}$$

$$D_{sp} = 50\text{mm}$$

$$V_{f1} = 4.78\text{m/s}$$

Since, Required diameter of suction pipe is  $50\text{mm}$ ,

### 2.2. Width of impeller

$$Q = V_0 \left[ \frac{\pi D_0^2}{4} - \frac{\pi D_H^2}{4} \right]$$

$$b_1 = \frac{Q}{\pi \times V_{f1} \times D_1}$$

$$b_1 = 0.03805\text{m}$$

$$D_0 = 0.06439\text{m}$$

$$b_1 = 38.05\text{mm}$$

$$D_0 \cong 64\text{mm}$$

### 2.3. Relative velocity at inlet

$$\therefore D_0 = D_1$$

$$\sin \theta = \frac{V_{f1}}{V_{r1}}$$

$\therefore$  Inlet diameter of impeller – ( $D_1$ )

$$V_{r1} = 21.25\text{m/s}$$

$$D_1 = 65\text{mm}$$

Outer diameter of impeller is  $240\text{mm}$  (standard diameter)

Since, Inlet diameter of impeller is  $70\text{mm}$ .

(Standard Diameter)

### 2.4. Velocity at outlet

$$U_2 = \frac{\pi \times D_2 \times N}{60 \times 1000}$$

$$U_2 = 70.37\text{m/s}$$

The normal range of discharge angle is  $20^\circ - 25^\circ$

$20^\circ$  (outlet angle of impeller)

$$V_{f1} = V_{f2} = 4.78\text{m/s}$$

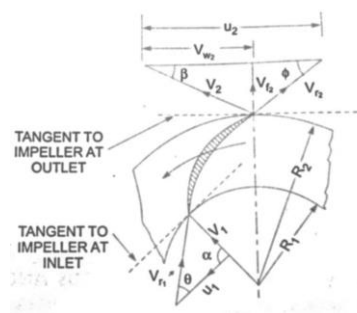

Fig.5: Velocity triangle

$$\tan \phi = \frac{V_{f2}}{U_2 - V_{w2}}$$

### 2.1. Inlet tip velocity

$$V_{w2} = 57.24\text{m/s}$$

2.5. Velocity angle at outlet

$$\tan \beta = \frac{V_{f2}}{V_{w2}}$$

$$\beta = 4.77^\circ$$

2.6. Relative velocity at outlet

$$V_{r2} = \sqrt{((U_2 - V_{w2})^2 + V_{f2}^2)}$$

$$V_{r2} = 13.97 \text{ m/s}$$

3. Design of hose pipe

The eye of the impeller is connected with the bottom of the collection drum with hose pipe

Therefore,  $D_0 = D_{HP} = 70 \text{ mm}$ .

3.1 Velocity inside the hose pipe

$$Q = A_{HP} \times V_{HP}$$

$$V_{HP} = 10.39 \text{ m/s}$$

3.2 Velocity inside the collecting tank

Selected tank with diameter 300mm

$$A_{HP} \times V_{HP} = A_{CT} \times V_{CT}$$

$$V_{CT} = 0.57 \text{ m/s}$$

3.3 Velocity at suction pipe

$$A_{CT} \times V_{CT} = A_{SP} \times V_{SP}$$

$$V_{SP} = 20.52 \text{ m/s}$$

As required velocity is 12.73m/s and we obtained the velocity at suction is 20.52 m/s so we can easily picked cotton from cotton boll.

iv. 2D & 3d model

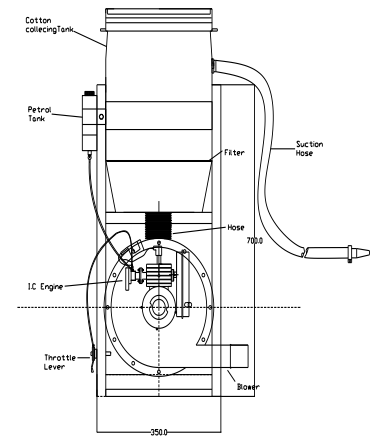

Fig.6: 2D model of cotton picker machine

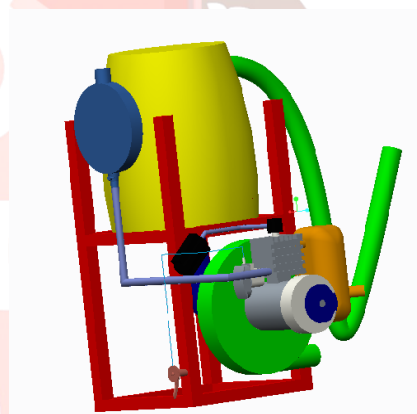

Fig.7: 3D model of cotton picker machine

v. CONCLUSION

The purpose of this project is to enhance the method of cotton picking by manual one and without degrading its quality. It will also help to increase the production at low cost.

VI. REFERENCES

1. Design & Analysis of Cotton Picking Machine in View of Cotton Fibre Strength  
Nikhil Gedam; Prof.A.K.Mahalle  
International Journal of Engineering

- Research and General Science Volume 3, Issue 3, May-June, 2015
2. "Performance evaluation of a manually operated cotton picker" Adebija J. A, and Jackson B. A. in African journal of agricultural research, vol. 8(29), pp. 3883-3887, 1 august 2013
  3. Determination of Variety Effect of a Simple Cotton Picking Machine on Design Parameters M. Bülent COŞKUN' Geliş Tarihi: 12.07.2002
  4. Quantitation of Fiber Quality and the Cotton Production-Processing Interface: A Physiologist's Perspective; Judith M. Bradow\* and Gayle H. Davidonis
  5. The Effect of Harvesting Procedures on Fiber and Yarn Quality of Ultra-Narrow-Row Cotton; David D. McAlister III and Clarence D. Rogers
  6. "A Study Of Mechanization of Cotton Harvesting In India: Implications For International Markets" Srinivasa Konduru, Fumiko Yamazaki & Mechel Paggi, Final Report: Cotton Inc. Project #10-275
  7. Evaluation of Portable Cotton Picker, International Journal of Agriculture Innovations and Research Volume 2, Issue 1, ISSN (Online) 2319-1473.
  8. Design data for machine elements, B. D. Shiwalkar
  9. A textbook of fluid mechanics and hydraulic machines, Dr. R. K. Bansal
  10. Expert System Design for Cotton Harvesting Using Shape and Fractal Features, Mahua Bhattacharya, Medhabi Verma, Vivek Shukla, CSIR CMERI Centre of Excellence for Farm Machinery.
  11. Performance evaluation of a manually operated cotton picker, Adebija J. A.\* and Jackson B. A. National Centre for Agricultural Mechanization, KM 20, Ilorin-Lokoja Highway, PMB 1525, Ilorin, Kwara State, Nigeria. African Journal of Agricultural Research Vol. 8(29), pp. 3883-3887, 1 August, 2013.